

Gear Pumps  
Standard Flange

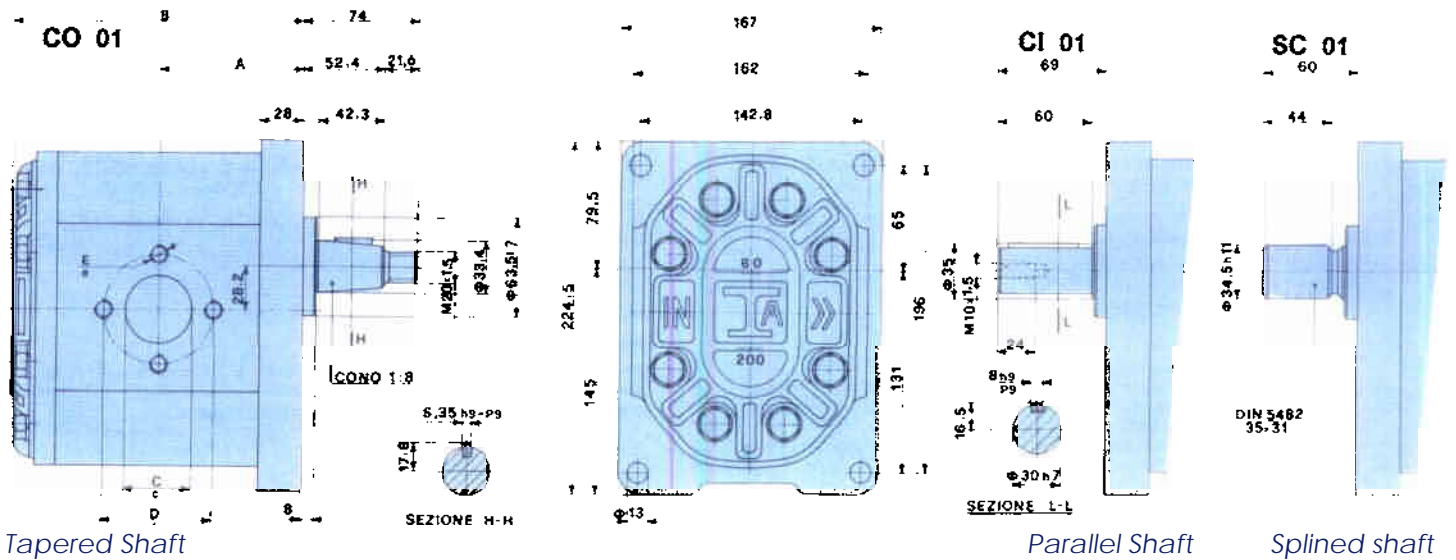

Installation dimensions



Tapered Shaft

Parallel Shaft

Splined shaft

Specification Data

Type	Capacity cc/rev Displacement at 1000 RPM litres/min.	Max pressure bar	Max speed rev/min.	A	B	Inlet			Outlet		
						C	D	E	c	d	e
TAP 60 - 200/60	60	280	3000	84	168	36	62	M10	30	56	M10
TAP 60 - 200/85	85	280	3000	89	178	36	62	M10	30	56	M10
TAP 60 - 200/106	106	235	2500	93	186	36	62	M10	30	56	M10
TAP 60 - 200/130	130	220	2500	97.5	195	45	72.5	M12	36	62	M10
TAP 60 - 200/148	148	210	2400	101	202	45	72.5	M12	36	62	M10
TAP 60 - 200/180	180	170	2400	107	214	56	92	M12	45	72.5	M12
TAP 60 - 200/200	200	150	2400	111	222	56	92	M12	45	72.5	M12

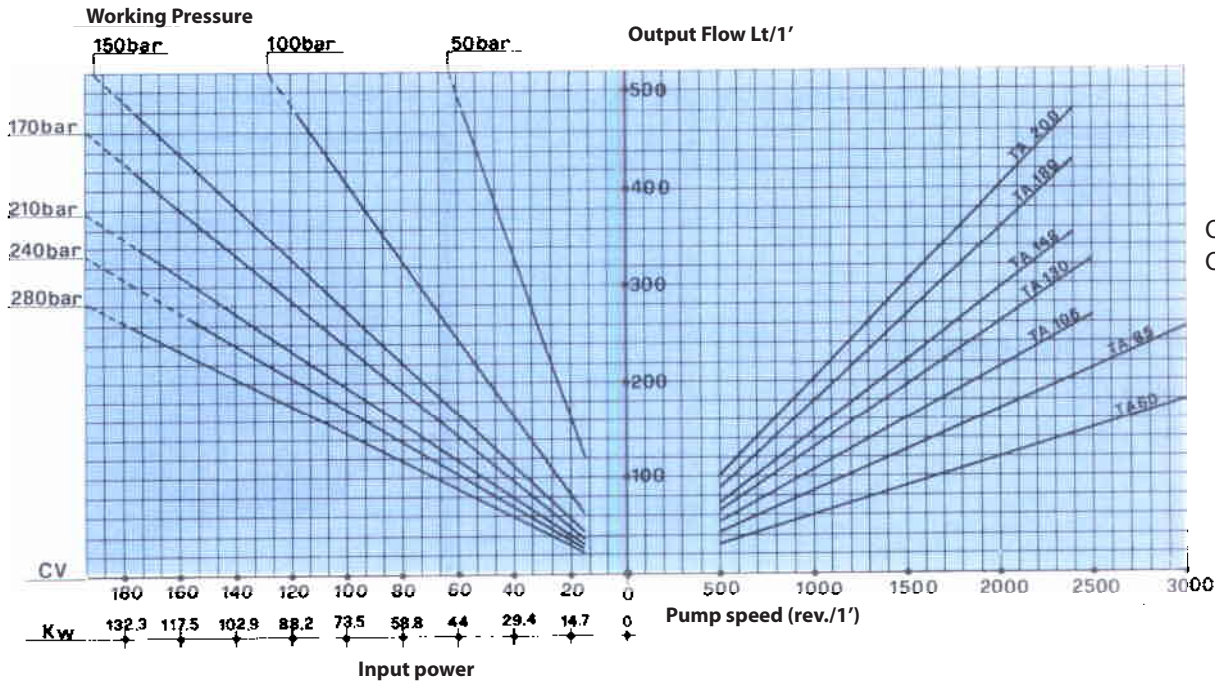

Oil temperature 50°C  
Oil viscosity 5°E

Typical overall efficiency at max pressure  
 $\eta_t = 89\% \div 92\%$

Typical volumetric efficiency at max pressure  
 $\eta_v = 94\% \div 96\%$

## Operating Instruction

### Pump Installation

Pump must be located with driving shaft coaxial to power take off. The drive system must not impose axial or radial load to pump shaft. For gear or belt drive please contact our Engineering Department.

### Hydraulic fluid

Use mineral based hydraulic oil with additive to resist oxidation, corrosion and foaming, or an engine oil.  
Recommended viscosity:  
Mineral oil 3÷5 °E 50 °C - Engine oil SAE 10, 20, 30 depending on environment temperature.  
Operating temperature range: -15 +80 °C  
Minimum viscosity: 1.45 °E  
Maximum viscosity during starting: 200°E

### Filtration

Ensure before filling the system that circuit is perfectly clean. Filters must be adequate in capacity, and preferably with blockage indicators.  
Filters must be changed according to operation instructions.  
Recommended filtering: Suction side - 90 mesh - Return side - 25 medium porosity.

### Piping instructions

Avoid sharp bends and restrictions on the circuit.  
Maximum inlet depression: 250 mm/Hg  
Maximum oil speed suction side: 0.5 ÷ 1.5 mt/sec.  
Maximum oil speed in outlet side: 3÷8 mt/sec.  
Maximum oil speed in return side: 2÷3 mt/sec.

### Pumps Coding

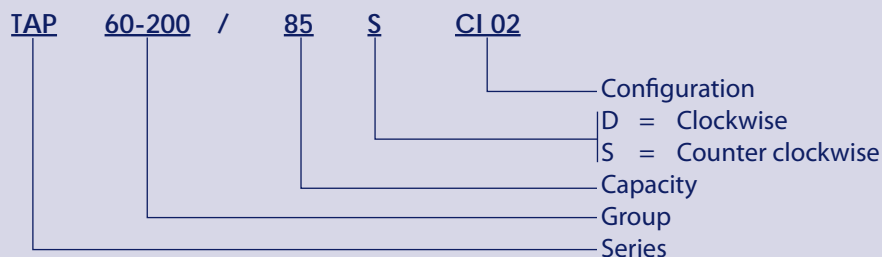

Gear Pumps  
SAE C Flange



Installation dimensions

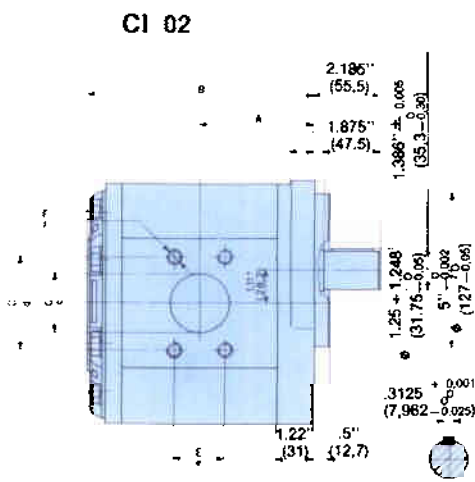

Parallel Shaft

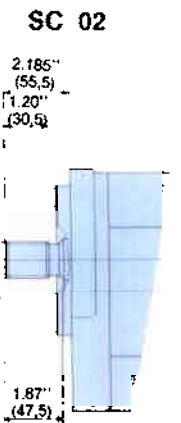
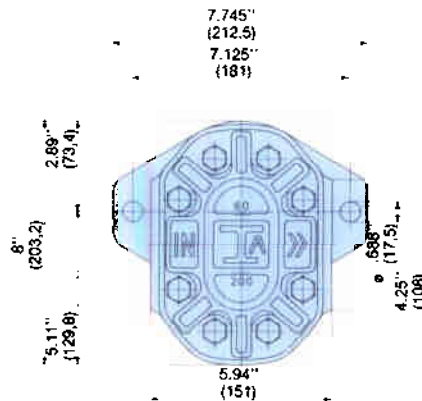

Splined shaft

Specification Data

Type	Capacity cc/rev Displacement at 1000 RPM litres/min.	Max pressure bar	Max speed rev/min.	A	B	Inlet				Outlet			
						C	D	E	F	c	d	e	f
TAP 60 - 200/60	60	280	3000	3.42 [87]	6.73 [171]	1½	2.75 [69.8]	1.40 [35.7]	½ - 13 UNC - 2B	1¼	2.31 [58.7]	1.18 [30.1]	7/16 - 14 UNC - 2B
TAP 60 - 200/85	85	280	3000	3.62 [92]	7.12 [181]	1½	2.75 [69.8]	1.40 [35.7]	½ - 13 UNC - 2B	1¼	2.31 [58.7]	1.18 [30.1]	7/16 - 14 UNC - 2B
TAP 60 - 200/106	106	235	2500	3.77 [96]	7.44 [189]	2	3.06 [77.7]	1.68 [42.8]	½ - 13 UNC - 2B	1½	2.75 [69.8]	1.40 [35.7]	½ - 13 UNC - 2B
TAP 60 - 200/130	130	220	2500	3.95 [100.5]	7.79 [198]	2	3.06 [77.7]	1.68 [42.8]	½ - 13 UNC - 2B	1½	2.75 [69.8]	1.40 [35.7]	½ - 13 UNC - 2B
TAB 60 - 200/148	148	210	2400	4.09 [104]	8.07 [205]	2	3.06 [77.7]	1.68 [42.8]	½ - 13 UNC - 2B	1½	2.75 [69.8]	1.40 [35.7]	½ - 13 UNC - 2B
TAB 60 - 200/180	180	170	2400	4.33 [110]	8.54 [217]	2	3.06 [77.7]	1.68 [42.8]	½ - 13 UNC - 2B	1½	2.75 [69.8]	1.40 [35.7]	½ - 13 UNC - 2B
TAB 60 - 200/200	200	150	2400	4.48 [114]	8.85 [225]	2	3.06 [77.7]	1.68 [42.8]	½ - 13 UNC - 2B	1½	2.75 [69.8]	1.40 [35.7]	½ - 13 UNC - 2B

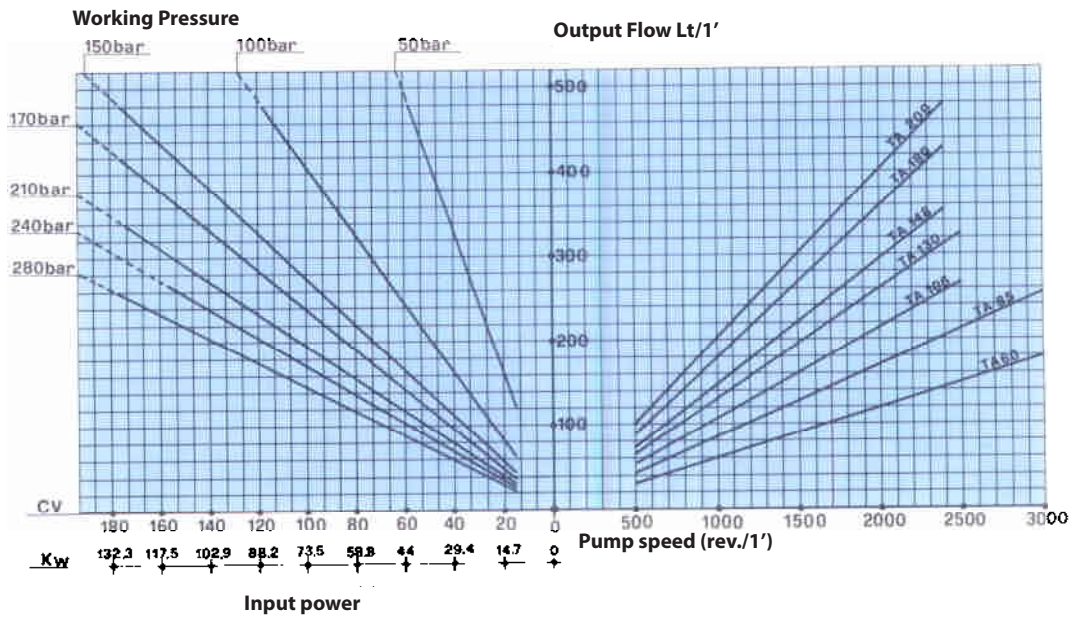

Oil temperature 50°C  
Oil viscosity 5°E

Typical overall efficiency at max pressure  
 $\eta_t = 89\% \div 92\%$

Typical volumetric efficiency at max pressure  
 $\eta_v = 94\% \div 96\%$

## Operating Instruction

### Pump Installation

Pump must be located with driving shaft coaxial to power take off. The drive system must not impose axial or radial load to pump shaft. For gear or belt drive please contact our Engineering Department.

### Hydraulic fluid

Use a mineral based hydraulic oil with additive to resist oxidation, corrosion and foaming, or an engine oil.

Recommended viscosity:

Mineral oil 3÷5 °E 50 °C - Engine oil SAE 10, 20, 30 depending on environment temperature.

Operating temperature range: -15 +80 °C

Minimum viscosity. 1.45 °E

Maximum viscosity during starting: 200 °E

### Filtration

Ensure, before filling the system, that circuit is perfectly clean. Filters must be adequate in capacity and preferably with blockage indicators.

Filters must be changed according to operating instructions.

Recommended filtering: Suction side - 90 mesh - Return side - 25 medium porosity.

### Piping instructions

Avoid sharp bends and restrictions on the circuit.

Maximum inlet depression: 250 mm/Hg

Maximum oil speed suction side: 0.5 ÷ 1.5 mt/sec.

Maximum oil speed in outlet side: 3÷8 mt/sec.

Maximum oil speed in return side: 2÷3 mt/sec.

### Pumps Coding

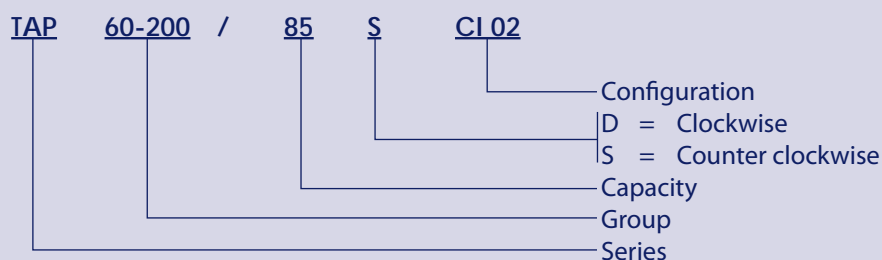



Tandem Gear Pumps  
Standard flange

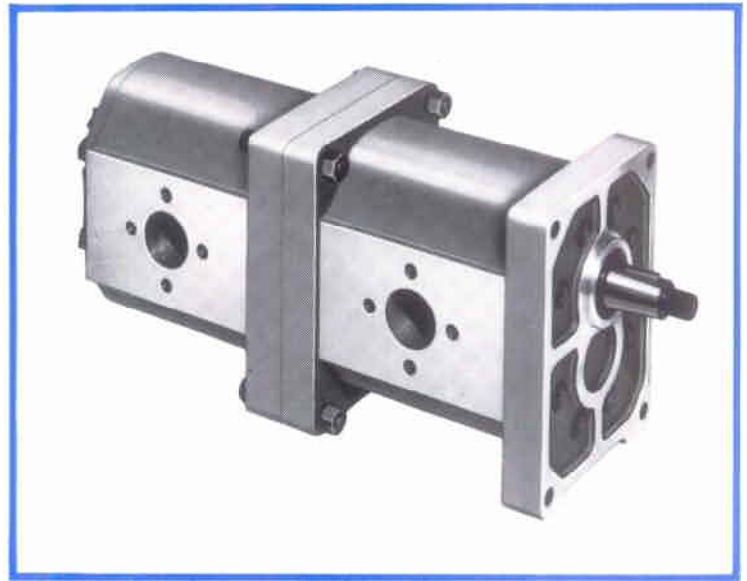

Installation dimensions

Valid only for geometrical dimensions.  
For technical performances see general catalogue.

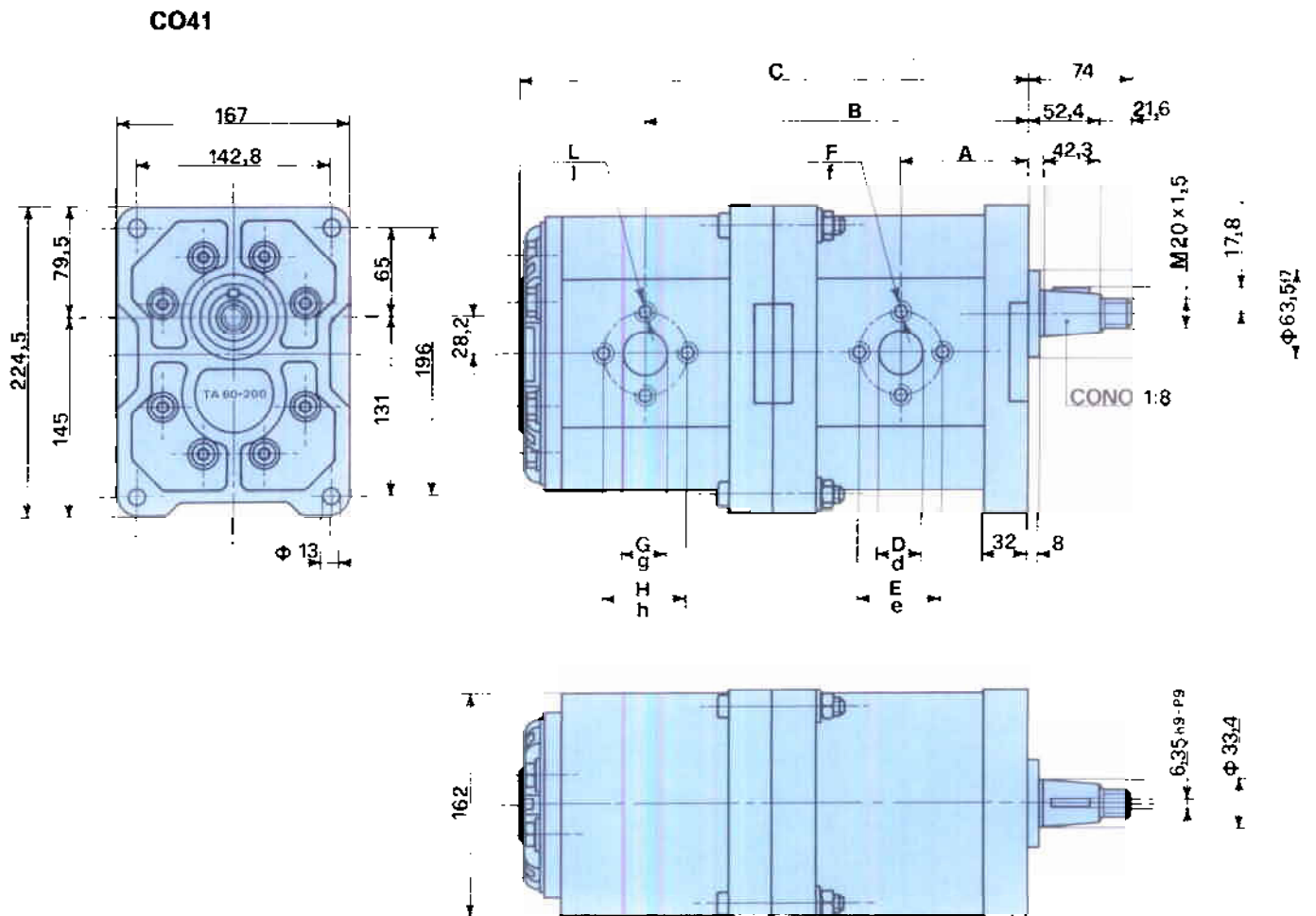

#### Specification Data

Type TAP 60-200 +TAP 60-200	Capacity cc/rev Displacement at 1000 RPM litres/min.	Max pressure bar		Max speed rev/min.	A	B	C	Inlet						Outlet					
		First pump	Second pump					D	E	F	G	H	L	d	e	f	g	h	l
60 + 60	60 + 60	280	280	3000	88	264	348	36	62	M10	36	62	M10	30	56	M10	30	56	M10
85 + 60	85 + 60	280	280	3000	93	274	358	36	62	M10	36	62	M10	30	56	M10	30	56	M10
85 + 85	85 + 85	250	250	3000	93	279	368	36	62	M10	36	62	M10	30	56	M10	30	56	M10
106 + 60	106 + 60	235	280	2500	97	282	366	36	62	M10	36	62	M10	30	56	M10	30	56	M10
106 + 85	106 + 85	200	245	2500	97	287	376	36	62	M10	36	62	M10	30	56	M10	30	56	M10
106 + 106	106 + 106	200	200	2500	97	291	384	36	62	M10	36	62	M10	30	56	M10	30	56	M10
130 + 60	130 + 60	205	260	2500	101.5	291	375	45	72.5	M12	36	62	M10	36	62	M10	30	56	M10
130 + 85	130 + 85	180	225	2500	101.5	296	385	45	72.5	M12	36	62	M10	36	62	M10	30	56	M10
130 + 106	130 + 106	175	185	2400	101.5	300	393	45	72.5	M12	36	62	M10	36	62	M10	30	56	M10
130 + 130	130 + 130	160	160	2400	101.5	304.5	402	45	72.5	M12	45	72.5	M12	36	62	M10	36	62	M10
148 + 60	148 + 60	185	250	2400	105	298	382	45	72.5	M12	36	62	M10	36	62	M10	30	56	M10
148 + 85	148 + 85	165	215	2400	105	303	392	45	72.5	M12	36	62	M10	36	62	M10	30	56	M10
148 + 106	148 + 106	160	175	2400	105	307	400	45	72.5	M12	36	62	M10	36	62	M10	30	56	M10
148 + 130	148 + 130	150	155	2400	105	311.5	409	45	72.5	M12	45	72.5	M12	36	62	M10	36	62	M10
148 + 148	148 + 148	140	140	2400	105	315	416	45	72.5	M12	45	72.5	M12	36	62	M10	36	62	M10
180 + 60	180 + 60	150	250	2400	111	310	394	56	90	M12	36	62	M10	45	72.5	M12	30	56	M10
180 + 85	180 + 85	135	215	2400	111	315	404	56	90	M12	36	62	M10	45	72.5	M12	30	56	M10
180 + 106	180 + 106	130	180	2400	111	319	412	56	90	M12	36	52	M10	45	72.5	M12	30	56	M10
180 + 130	180 + 130	120	160	2400	111	319	421	56	90	M12	45	72.5	M12	45	72.5	M12	36	62	M10
180 + 148	180 + 148	115	140	2400	111	327	428	56	90	M12	45	72.5	M12	45	72.5	M12	36	62	M10
180 + 180	180 + 180	115	115	2400	111	333	440	56	90	M12	56	90	M12	45	72.5	M12	45	72.5	M12
200 + 60	200 + 60	135	255	2400	115	318	402	56	90	M12	36	62	M10	45	72.5	M12	30	56	M10
200 + 85	200 + 85	120	220	2400	115	323	412	56	90	M12	36	62	M10	45	72.5	M12	30	56	M10
200 + 106	200 + 106	115	180	2400	115	327	420	56	90	M12	36	62	M10	45	72.5	M12	30	56	M10
200 + 130	200 + 130	110	160	2400	115	331.5	429	56	90	M12	45	72.5	M12	45	72.5	M12	36	62	M10
200 + 148	200 + 148	105	145	2400	115	335	436	56	90	M12	45	72.5	M12	45	72.5	M12	36	62	M10
200 + 180	200 + 180	105	115	2400	115	341	448	56	90	M12	56	90	M12	45	72.5	M12	45	72.5	M12
200 + 200	200 + 200	105	105	2400	115	345	456	56	90	M12	56	90	M12	45	72.5	M12	45	72.5	M12

Typical performance and operating instruction please apply to single pump leaflet  
Fluids' separation between two stages is not provided

#### Ordering Code

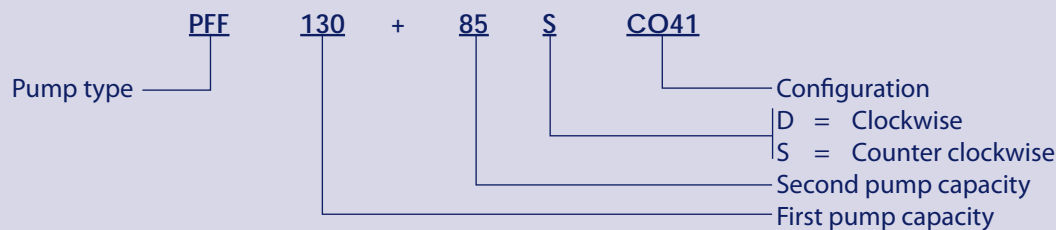

© 2010 Turolia OpenCircuitGear™. All rights reserved.

Turolia OCG accepts no responsibility for possible errors in catalogs, brochures and other printed material. Turolia OCG reserves the right to alter its products without prior notice. This also applies to products already ordered provided that such alterations can be made without affecting agreed specifications. All trademarks in this material are properties of their respective owners. Sauer-Danfoss, Turolia, Turolia OpenCircuitGear, Turolia OCG, OpenCircuitGear, Fast Lane and PLUS+1 are trademarks of the Sauer-Danfoss Group.